

## Fluorescein-EX Protein Labeling Kit (F10240)

### Quick Facts

#### Storage upon receipt:

- 4°C
- Do not freeze

**Abs/Em:** 494/518 nm

- Purification columns, three
- Column funnels, three
- Foam column holders, three
- Disposable pipets, three
- Collection tubes, three 4 mL tubes

#### Storage

Store the kit at 4°C. DO NOT FREEZE.

### Introduction

Molecular Probes' Fluorescein-EX Protein Labeling Kit provides a convenient means to label proteins with fluorescein. This kit contains everything that is required to perform three separate labeling reactions and to purify the resulting conjugates. Each of the 3 vials of the reactive dye provided in the kit is sufficient for labeling ~1 mg of an IgG antibody, although other proteins can also be labeled.

The fluorescein-EX dye (Figure 1) has a succinimidyl ester moiety that reacts efficiently with primary amines of proteins to form stable dye–protein conjugates. The succinimidyl ester group is separated from the fluorophore by a seven-atom spacer (X) to minimize interaction between the fluorophore and the protein to which the dye is conjugated. The absorption and fluorescence emission maxima for fluorescein-EX labeled proteins are approximately 494 nm and 518 nm, respectively.

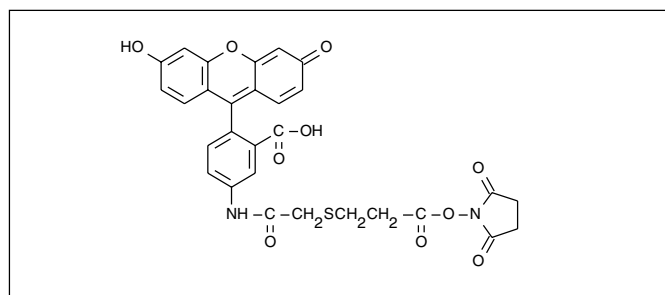

Figure 1. Fluorescein-5-EX, succinimidyl ester (MW 591).

### Materials

#### Contents

- **Fluorescein-EX reactive dye** (Component A), three vials, each containing a magnetic stir bar
- **Sodium bicarbonate** (MW = 84, Component B), 84 mg
- **Purification resin** (Component C), ~25 mL
- **10X Elution buffer** (Component D), ~25 mL

### Protein Preparation

**IMPORTANT:** For optimal labeling efficiency, the purified protein must be in a buffer free of ammonium ions and primary amines. If the protein is in an unsuitable buffer (e.g. Tris or glycine), the buffer should be replaced with phosphate-buffered saline (PBS) by dialysis or another method. Impure proteins (e.g. antibodies in crude serum) will not label well. The presence of low concentrations of sodium azide ( $\leq 3$  mM) or thimerosal ( $\leq 1$  mM) will not interfere with the conjugation reaction.

This kit can be used to label virtually any protein, although the following protocol has been optimized for labeling IgG antibodies. Each vial of reactive dye contains the appropriate amount of dye to label approximately 1 mg of IgG (MW ~145,000) as 0.5 mL of IgG solution at 2 mg/mL.

For tips on optimizing the procedure for other proteins or for antibody solutions at lower concentrations, see **Tips for Using the Kit with Other Proteins and/or Concentrations and Troubleshooting**.

### Labeling Reaction

**1.1** Prepare a 1 M solution of sodium bicarbonate by adding 1 mL of deionized water ( $\text{dH}_2\text{O}$ ) to the provided vial of sodium bicarbonate (Component B). Vortex or pipet up and down until fully dissolved. The bicarbonate solution, which will have a pH ~8.3, can be stored at 4°C for up to two weeks.

**1.2** If the protein concentration is greater than 2 mg/mL, the protein should be diluted to 2 mg/mL in a suitable buffer, e.g. PBS or 0.1 M sodium bicarbonate.

**1.3** To 0.5 mL of the 2 mg/mL protein solution, add 50  $\mu\text{L}$  of 1 M bicarbonate (prepared in step 1.1).

*Bicarbonate, pH ~8.3, is added to raise the pH of the reaction mixture, since succinimidyl esters react efficiently at pH 7.5–8.5.*

**1.4** Allow a vial of reactive dye to warm to room temperature. Transfer the protein solution from step 1.3 to the vial of reactive dye. This vial contains a magnetic stir bar. Cap the vial and

invert a few times to fully dissolve the dye. Stir the reaction mixture for 1 hour at room temperature.

*Because preparation of the purification column takes ~15 minutes, you may wish to begin pouring the column (see **Purification of the Labeled Protein**) during the labeling reaction.*

---

## Purification of the Labeled Protein

**2.1** Assemble the column and position it upright (see Figure 2): Attach a funnel to the top of a column. Gently insert the column through the X-cut in one of the provided foam holders. Using the foam holder, secure the column with a clamp to a ringstand. Carefully remove the cap from the bottom of the column.

*The foam holder is provided to prevent the clamp from damaging the column.*

**2.2** Prepare elution buffer by diluting the 10X stock (Component D) 10-fold in dH<sub>2</sub>O. Typically, less than 10 mL will be required for each purification. Set aside until step 2.5.

*The 10X elution buffer (10X PBS) contains 0.1 M potassium phosphate, 1.5 M NaCl, pH 7.2, with 2 mM sodium azide. The 10X stock should be warmed to room temperature prior to use to ensure that the buffer is fully dissolved. Sufficient elution buffer is included to allow washing of the columns for reuse, if desired.*

**2.3** Using one of the provided pipets, stir the purification resin (Component C) thoroughly to ensure a homogeneous suspension. Pipet the resin into the column, allowing excess buffer to drain away into a small beaker or other container. Resin should be packed into the column until the resin is ~3 cm from the top of the column.

*The purification resin, which is packaged in PBS containing 2 mM sodium azide, is designed to separate free dye from proteins with MW >15,000.*

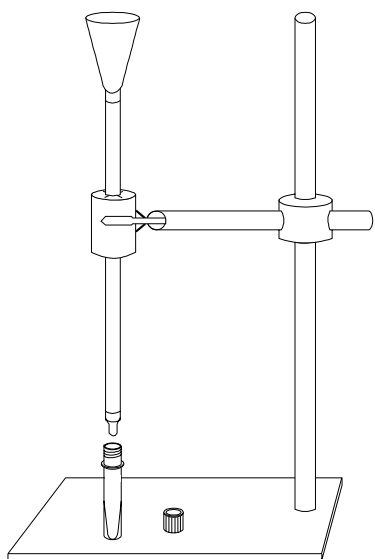

**Figure 2.** Column assembly.

**2.4** Allow the excess buffer to drain into the column bed. Do not worry about the column drying out, since the matrix will remain hydrated. Carefully load the reaction mixture from step 1.4 onto the column. You may wish to remove the column funnel to load the sample. Allow the mixture to enter the column resin. Rinse the reaction vial with ~100 µL of elution buffer and apply to the column. Allow this solution to enter the column.

**2.5** Replace the funnel if it was removed for sample loading. Slowly add elution buffer (prepared in step 2.2), taking care not to disturb the column bed. Continue adding elution buffer until the labeled protein has been eluted (typically about 30 minutes).

*IMPORTANT: Collect, and retain as fractions, all of the eluted buffer.*

**2.6** As the column runs, periodically illuminate the column with a handheld UV lamp. You should observe two fluorescent bands, which represent the separation of the labeled protein from the unincorporated dye. Collect the first band, which contains the labeled protein, into one of the provided collection tubes. Add elution buffer to the column as necessary. Do not collect the slower moving band, which consists of unincorporated dye.

*Once the fraction containing the labeled protein has been successfully collected, all other fractions of eluted buffer may be discarded. In rare instances where there is no discernable band corresponding to labeled protein, the retained fractions can be used to recover any unlabeled protein.*

---

## Determination of Degree of Labeling

**3.1** Measure the absorbance of the conjugate solution at 280 nm and 494 nm ( $A_{280}$  and  $A_{494}$ ) in a cuvette with a 1 cm pathlength.

*Dilution of the sample may be necessary.*

**3.2** Calculate the concentration of protein in the sample:

$$\text{protein concentration (M)} = \frac{[A_{280} - (A_{494} \times 0.20)] \times \text{dilution factor}}{203,000}$$

where 203,000 cm<sup>-1</sup>M<sup>-1</sup> is the molar extinction coefficient of a typical IgG and 0.20 is a correction factor to account for absorption of the dye at 280 nm.

*Non-IgG proteins will likely have significantly different molar extinction coefficients.*

**3.3** Calculate the degree of labeling:

$$\text{moles dye per mole protein} = \frac{A_{494} \times \text{dilution factor}}{68,000 \times \text{protein concentration (M)}}$$

where 68,000 cm<sup>-1</sup>M<sup>-1</sup> is the approximate molar extinction coefficient of the fluorescein-EX dye at pH 8 at 494 nm. For IgGs, we find that optimal labeling is achieved with 4–8 moles of fluorescein-EX dye per mole of antibody.

---

## Storage and Handling of Conjugates

Store the labeled protein — which will be in PBS, pH 7.2, containing ~2 mM sodium azide — at 4°C, protected from light. If the final concentration of purified protein conjugate is less than 1 mg/mL, add bovine serum albumin (BSA) or other stabilizing protein to 1–10 mg/mL. The conjugate should be stable at 4°C for several months. For long-term storage, divide the solution into small aliquots and freeze at -20°C. **AVOID REPEATED FREEZING AND THAWING. PROTECT FROM LIGHT.**

It is a good practice to centrifuge conjugate solutions in a microcentrifuge before use; only the supernatant should then be used in the experiment. This step will remove any aggregates that may have formed during storage.

---

## Tips for Using the Kit with Other Proteins and/or Concentrations

**Proteins at less than 2 mg/mL.** Proteins at concentrations less than 2 mg/mL will not label as efficiently. If the protein cannot be concentrated to ~2 mg/mL, you may wish to use less than 1 mg protein per reaction to increase the molar ratio of dye to protein. In addition, using a dilute protein solution, especially at <1 mg/mL, will make it more difficult to efficiently remove the unconjugated dye from the dye-labeled protein with acceptable yields, since the provided purification columns are designed to purify conjugates from a total volume of less than 1 mL. For reaction volumes greater than 1 mL, you can divide the solution of the conjugate and apply it to multiple purification columns or, to avoid further dilution of the conjugate, you can remove free dye by extensive dialysis.

**Proteins with MW other than ~145,000.** Typically, lower MW proteins require fewer dye molecules and higher MW proteins require more dye molecules per protein for optimal labeling. For this reason, we recommend initially performing the reaction with 0.5 mL of 2 mg/mL protein solution, as described for IgGs. The labeling conditions can then be optimized based on the initial results, if desired.

*Please note that proteins with a MW less than 15,000 should not be applied to the size exclusion column provided with this kit. An alternate column matrix can be used, or the free dye can be removed from the conjugate by extensive dialysis.*

---

## Troubleshooting

**Under-labeling.** If calculations indicate that the protein is labeled with significantly less than four moles of fluorophore per mole of a 145,000 dalton protein, your protein may be under-labeled. A number of conditions can cause a protein to label inefficiently:

- Trace amounts of primary amine-containing components in the buffer will react with the dye and decrease the efficiency of protein labeling. If your protein has been in amine-containing buffers (e.g. Tris or glycine), dialyze *extensively* versus PBS before labeling.
- Dilute solutions of protein ( $\leq 1$  mg/mL) will not label efficiently. Please see *Proteins at less than 2 mg/mL*.
- The addition of sodium bicarbonate (step 1.3) is designed to raise the pH of the reaction mixture to ~8, as succinimidyl esters react most efficiently with primary amines at slightly alkaline pH. If the protein solution is strongly buffered at a lower pH, the addition of bicarbonate will not raise the pH to the optimal level. Either more bicarbonate can be added, or the buffer can be exchanged with PBS, which is only weakly buffered, or with 0.1 M sodium bicarbonate, pH 8.3, by dialysis or other method prior to starting the reaction.
- Because proteins, including different antibodies, react with fluorophores at different rates and retain biological activity at different degrees of dye labeling, the standard protocol may not always result in optimal labeling. To increase the amount of labeling, you can relabel the same protein sample, or you can label a new protein sample using either less protein or more reactive dye per reaction. To increase the amount of dye in the reaction, you can combine the contents of two vials of reactive dye together. Some researchers obtain better labeling with overnight incubations at 4°C after an initial incubation of one hour at room temperature.

**Over-labeling.** If calculations indicate that the protein conjugate is labeled with significantly more than eight moles of fluorophore per mole of a 145,000 dalton protein, your protein may be over-labeled. Although conjugates with a high number of attached dye molecules may be acceptable for use, over-labeling can cause aggregation of the protein conjugate and can also reduce the antibody's specificity for its antigen — both of which can lead to nonspecific staining. Over-labeling can also cause fluorescence quenching of the attached dyes, which will decrease the fluorescence of the conjugate. To reduce the amount of labeling next time, you can either add more protein to your reaction to decrease the molar ratio of dye to protein or allow the reaction to proceed for a shorter time.

**Inefficient removal of free dye.** Although we have had good success in removing free dye from protein conjugates with the provided columns, it is possible that trace amounts of free dye will remain in the conjugate solution after purification, particularly if a low molecular weight protein is labeled. The presence of free dye, which can be determined by thin layer chromatography, will result in erroneously high calculated values for the degree of labeling (see *Determination of Degree of Labeling*). Remaining traces of free dye can be removed by applying the conjugate to another column or by extensive dialysis.

---

**Product List** *Current prices may be obtained from our Web site or from our Customer Service Department.*

<b>Cat #</b>	<b>Product Name</b>	<b>Unit Size</b>
F10240	Fluorescein-EX Protein Labeling Kit *3 labelings* .....	1 kit

---

**Contact Information**

Further information on Molecular Probes products, including product bibliographies, is available from your local distributor or directly from Molecular Probes. Customers in Europe, Africa and the Middle East should contact our office in Leiden, the Netherlands. All others should contact our Technical Assistance Department in Eugene, Oregon.

Please visit our Web site — [www.probes.com](http://www.probes.com) — for the most up-to-date information

**Molecular Probes, Inc.**

29851 Willow Creek Road, Eugene, OR 97402  
Phone: (541) 465-8300 • Fax: (541) 335-0504

**Customer Service:** 6:00 am to 4:30 pm (Pacific Time)  
Phone: (541) 335-0338 • Fax: (541) 335-0305 • [order@probes.com](mailto:order@probes.com)

**Toll-Free Ordering for USA and Canada:**  
Order Phone: (800) 438-2209 • Order Fax: (800) 438-0228

**Technical Assistance:** 8:00 am to 4:00 pm (Pacific Time)  
Phone: (541) 335-0353 • Toll-Free: (800) 438-2209  
Fax: (541) 335-0238 • [tech@probes.com](mailto:tech@probes.com)

**Molecular Probes Europe BV**

Poortgebouw, Rijnsburgerweg 10  
2333 AA Leiden, The Netherlands  
Phone: +31-71-5233378 • Fax: +31-71-5233419

**Customer Service:** 9:00 to 16:30 (Central European Time)  
Phone: +31-71-5236850 • Fax: +31-71-5233419  
[eurorder@probes.nl](mailto:eurorder@probes.nl)

**Technical Assistance:** 9:00 to 16:30 (Central European Time)  
Phone: +31-71-5233431 • Fax: +31-71-5241883  
[eurotech@probes.nl](mailto:eurotech@probes.nl)

*Molecular Probes products are high-quality reagents and materials intended for research purposes only. These products must be used by, or directly under the supervision of, a technically qualified individual experienced in handling potentially hazardous chemicals. Please read the Material Safety Data Sheet provided for each product; other regulatory considerations may apply.*

Several Molecular Probes products and product applications are covered by U.S. and foreign patents and patents pending. Our products are not available for resale or other commercial uses without a specific agreement from Molecular Probes, Inc. We welcome inquiries about licensing the use of our dyes, trademarks or technologies. Please submit inquiries by e-mail to [busdev@probes.com](mailto:busdev@probes.com). All names containing the designation ® are registered with the U.S. Patent and Trademark Office.

Copyright 2004, Molecular Probes, Inc. All rights reserved. This information is subject to change without notice.