

Alexa Fluor® 633 Protein Labeling Kit (A20170)

Quick Facts

Storage upon receipt:

Component A

- $\leq -20^{\circ}\text{C}$
- Protect from light
- Protect from moisture

Components B

- $2-6^{\circ}\text{C}$
- Protect from moisture

Components C and D

- $2-6^{\circ}\text{C}$ only, DO NOT FREEZE COMPONENT C

Abs/Em of conjugate: 621/639 nm

The relative height of the secondary absorption peak can change with the degree of labeling and, in some instances, can actually be the higher of the two absorption peaks. One benefit of the dual excitation peaks is that in addition to filter sets optimized for ~ 630 nm excitation, Texas Red® dye longpass filters can be used to visualize these conjugates. However, for maximal fluorescence output, excitation at ~ 630 nm is always more efficient than excitation at ~ 580 nm (Figure 1).

The Alexa Fluor 633 protein Labeling Kit contains everything that is required to perform three separate labeling reactions and purify the resulting conjugates. The Alexa Fluor 633 reactive dye (MW ~ 1200) has a succinimidyl ester moiety that reacts efficiently with primary amines of proteins to form stable dye–protein conjugates. Each of the three vials of reactive dye provided in the kit is sufficient for labeling ~ 1 mg of an IgG antibody, although other proteins can also be labeled.

Materials

Contents

- **Alexa Fluor 633 reactive dye** (Component A), three vials, each containing a magnetic stir bar
- **Sodium bicarbonate** (MW = 84, Component B), 84 mg
- **Purification resin** (Component C), ~ 25 mL
- **10X Elution buffer** (Component D), ~ 25 mL
- **Purification columns**, three
- **Column funnels**, three
- **Foam column holders**, three
- **Disposable pipets**, three
- **Collection tubes**, three 4 mL tubes

Storage

Upon receipt, store Component A at $\leq 20^{\circ}\text{C}$ and Components B–D at $2-6^{\circ}\text{C}$. DO NOT FREEZE THE PURIFICATION RESIN (Component C). Protect the reactive dye (Component A) from light. The reactive dye and sodium bicarbonate (Component B) should be protected from moisture. When stored properly, the kit components should be stable for at least three months.

Protein Preparation

IMPORTANT: For optimal labeling efficiency, purified protein must be in a buffer free of ammonium ions or primary amines. If the protein is in an unsuitable buffer (e.g. Tris or glycine), the buffer should be replaced with phosphate-buffered saline (PBS) by dialysis or another method. Impure proteins (e.g. antibodies in crude serum) will not label well. The presence of low concentrations of sodium azide (≤ 3 mM) or thimerosal (≤ 1 mM) will not interfere with the conjugation reaction.

Introduction

Molecular Probes Alexa Fluor® 633 Protein Labeling Kit provides a convenient means to label proteins with our superior Alexa Fluor 633 dye. The exceptionally bright and photostable Alexa Fluor 633 dye was developed to be optimally excited with two increasingly popular excitation sources, the 633 nm line of the He-Ne laser and the 635 nm line of the red diode laser.

Alexa Fluor 633 dye-labeled proteins have absorption and fluorescence emission maxima of approximately 632 nm and 647 nm, respectively, with a secondary absorption peak at ~ 580 nm.

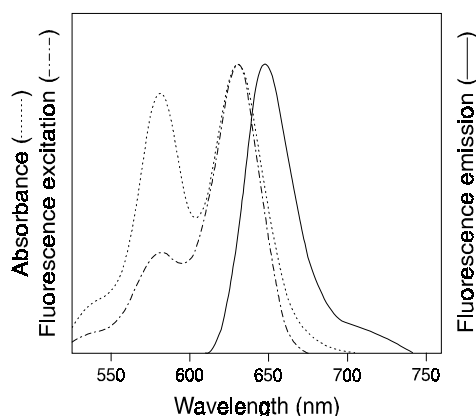

Figure 1. Normalized absorption, excitation and emission spectra of Alexa Fluor 633 conjugated to goat anti-hamster IgG in pH 7.2 buffer.

This kit can be used to label virtually any protein, although the following protocol has been optimized for labeling IgG antibodies. Each vial of reactive dye contains the appropriate amount of dye to label approximately 1 mg of IgG (MW ~145,000) as 0.5 mL of IgG solution at 2 mg/mL.

*For tips on optimizing the procedure for other proteins or for antibody solutions at lower concentrations, see **Tips for Using the Kit with Other Proteins and/or Concentrations and Troubleshooting.***

Labeling Reaction

1.1 Prepare a 1 M solution of sodium bicarbonate by adding 1 mL of deionized water (dH₂O) to the provided vial of sodium bicarbonate (Component B). Vortex or pipet up and down until fully dissolved. The bicarbonate solution, which will have a pH ~8.3, can be stored at 4°C for up to two weeks.

1.2 If the protein concentration is greater than 2 mg/mL, the protein should be diluted to 2 mg/mL in a suitable buffer, e.g. PBS or 0.1 M sodium bicarbonate.

1.3 To 0.5 mL of the 2 mg/mL protein solution, add 50 µL of 1 M bicarbonate (prepared in step 1.1).

Bicarbonate, pH ~8.3, is added to raise the pH of the reaction mixture, since succinimidyl esters react efficiently at pH 7.5–8.5.

1.4 Allow a vial of reactive dye to warm to room temperature. Transfer the protein solution from step 1.3 to the vial of reactive dye. This vial contains a magnetic stir bar. Cap the vial and invert a few times to fully dissolve the dye. Stir the reaction mixture for 1 hour at room temperature.

*Because preparation of the purification column takes ~15 minutes, you may wish to begin pouring the column (see **Purification of the Labeled Protein**) during the labeling reaction.*

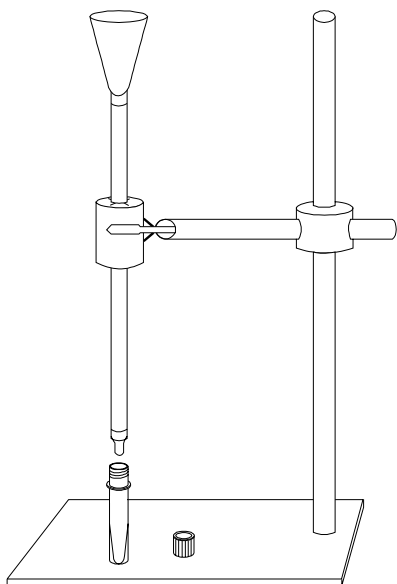

Figure 2. Column assembly.

Purification of the Labeled Protein

2.1 Assemble the column and position it upright (see Figure 2): Attach a funnel to the top of a column. Gently insert the column through the X-cut in one of the provided foam holders. Using the foam holder, secure the column with a clamp to a ringstand. Carefully remove the cap from the bottom of the column.

The foam holder is provided to prevent the clamp from damaging the column.

2.2 Prepare elution buffer by diluting the 10X stock (Component D) 10-fold in dH₂O. Typically, less than 10 mL will be required for each purification. Set aside until step 2.5.

The 10X elution buffer (10X PBS) contains 0.1 M potassium phosphate, 1.5 M NaCl, pH 7.2, with 2 mM sodium azide. The 10X stock should be warmed to room temperature prior to use to ensure that the buffer is fully dissolved. Sufficient elution buffer is included to allow washing of the columns for reuse, if desired.

2.3 Using one of the provided pipets, stir the purification resin (Component C) thoroughly to ensure a homogeneous suspension. Pipet the resin into the column, allowing excess buffer to drain away into a small beaker or other container. Resin should be packed into the column until the resin is ~3 cm from the top of the column.

Component C, Bio-Rad BioGel P-30 Fine size exclusion purification resin, is designed to separate free dye from proteins with MW > 40,000. This is packaged in PBS containing 2 mM sodium azide. For smaller proteins, gel filtration media of a suitable molecular weight cutoff should be selected. Labeled peptides may be separated from free dye by TLC or HPLC.

2.4 Allow the excess buffer to drain into the column bed. Do not worry about the column drying out, since the matrix will remain hydrated. Make certain the buffer elutes through the column with a consistently even flow prior to adding the reaction mixture. If the flow of buffer is slow or stalled, repack the column. Carefully load the reaction mixture from step 1.4 onto the column. You may wish to remove the column funnel to load the sample. Allow the mixture to enter the column resin. Rinse the reaction vial with ~100 µL of elution buffer and apply to the column. Allow this solution to enter the column.

2.5 Replace the funnel if it was removed for sample loading. Slowly add elution buffer (prepared in step 2.2), taking care not to disturb the column bed. Continue adding elution buffer until the labeled protein has been eluted (typically about 30 minutes).

IMPORTANT: Collect, and retain as fractions, all of the eluted buffer.

2.6 As the column runs, you should observe two colored bands, which represent the separation of labeled protein from unincorporated dye. Collect the first colored band, which contains the labeled protein, into one of the provided collection tubes. Add elution buffer to the column as necessary. Do not collect the slower moving band, which consists of unincorporated dye.

Once the fraction containing the labeled protein has been successfully collected, all other fractions of eluted buffer may be discarded. In rare instances where there is no discernable band corresponding to labeled protein, the retained fractions can be used to recover any unlabeled protein.

Determination of Degree of Labeling

3.1 Measure the absorbance of the conjugate solution at 280 nm and 632 nm (A_{280} and A_{632}) in a cuvette with a 1 cm pathlength.

Dilution of the sample may be necessary.

3.2 Calculate the concentration of protein in the sample:

$$\text{protein concentration (M)} = \frac{[A_{280} - (A_{632} \times 0.55)] \times \text{dilution factor}}{203,000}$$

where 203,000 $\text{cm}^{-1}\text{M}^{-1}$ is the molar extinction coefficient of a typical IgG and 0.55 is a correction factor to account for absorption of the dye at 280 nm.

Non-IgG proteins will likely have significantly different molar extinction coefficients.

3.3 Calculate the degree of labeling:

$$\text{moles dye per mole protein} = \frac{A_{632} \times \text{dilution factor}}{100,000 \times \text{protein concentration (M)}}$$

where 100,000 $\text{cm}^{-1}\text{M}^{-1}$ is the approximate molar extinction coefficient of the Alexa Fluor 633 dye at 632 nm. For IgGs, we find that optimal labeling is achieved with 1.5–4 moles of Alexa Fluor 633 dye per mole of antibody.

Storage and Handling of Conjugates

Store the labeled protein — which will be in PBS, pH 7.2, containing ~2 mM sodium azide — at 4°C, protected from light. If the final concentration of purified protein conjugate is less than 1 mg/mL, add bovine serum albumin (BSA) or other stabilizing protein to 1–10 mg/mL. The conjugate should be stable at 4°C for several months. For long-term storage, divide the solution into small aliquots and freeze at -20°C. **AVOID REPEATED FREEZING AND THAWING. PROTECT FROM LIGHT.**

It is a good practice to centrifuge conjugate solutions in a microcentrifuge before use; only the supernatant should then be used in the experiment. This step will remove any aggregates that may have formed during storage.

Tips for Using the Kit with Other Proteins and/or Concentrations

Proteins at less than 2 mg/mL. Proteins at concentrations less than 2 mg/mL will not label as efficiently. If the protein cannot be concentrated to ~2 mg/mL, you may wish to use less than 1 mg protein per reaction to increase the molar ratio of dye to protein. In addition, using a dilute protein solution, especially at <1 mg/mL, will make it more difficult to efficiently remove the unconjugated dye from the dye-labeled protein with acceptable yields, since the provided purification columns are designed to purify conjugates from a total volume of less than 1 mL. For reaction volumes greater than 1 mL, you can divide the solution of the conjugate and apply it to multiple purification columns or, to avoid further dilution of the conjugate, you can remove free dye by extensive dialysis.

Proteins with MW other than ~145,000. Typically, lower MW proteins require fewer dye molecules and higher MW proteins require more dye molecules per protein for optimal labeling. For this reason, we recommend initially performing the reaction with 0.5 mL of 2 mg/mL protein solution, as described for IgGs. The labeling conditions can then be optimized based on the initial results, if desired.

Troubleshooting

Under-labeling. If calculations indicate that the protein is labeled with significantly less than 1.5 moles of fluorophore per mole of 145,000 dalton protein, your protein is probably under-labeled. A number of conditions can cause a protein to label inefficiently:

- Trace amounts of primary amine-containing components in the buffer will react with the dye and decrease the efficiency of protein labeling. If your protein has been in amine-containing buffers (e.g. Tris or glycine), dialyze *extensively* versus PBS before labeling.
- Dilute solutions of protein (≤ 1 mg/mL) will not label efficiently. Please see *Proteins at less than 2 mg/mL*, above.
- The addition of sodium bicarbonate (step 1.3) is designed to raise the pH of the reaction mixture to ~8, as succinimidyl esters react most efficiently with primary amines at slightly alkaline pH. If the protein solution is strongly buffered at a lower pH, the addition of bicarbonate will not raise the pH to the optimal level. Either more bicarbonate can be added, or the buffer can be exchanged with PBS, which is only weakly buffered, or with 0.1 M sodium bicarbonate, pH 8.3, by dialysis or other method prior to starting the reaction.
- Because proteins, including different antibodies, react with fluorophores at different rates and retain biological activity at different degrees of dye labeling, the standard protocol may not always result in optimal labeling. To increase the amount of labeling, you can relabel the same protein sample, or you can label a new protein sample using either less protein or more reactive dye per reaction. To increase the amount of dye in the reaction, you can combine the contents of two vials of reactive dye together. Some researchers obtain better labeling with overnight incubations at 4°C after an initial incubation of one hour at room temperature.

Over-labeling. If calculations indicate that the protein conjugate is labeled with significantly more than four moles of fluorophore per mole of 145,000 dalton protein, your protein is probably over-labeled. Although conjugates with a high number of attached dye molecules may be acceptable for use, over-labeling can cause aggregation of the protein conjugate and can also reduce the antibody's specificity for its antigen — both of which can lead to nonspecific staining. Over-labeling can also cause fluorescence quenching of the attached dyes, which will decrease the fluorescence of the conjugate. To reduce the amount of labeling next time, you can either add more protein to your reaction to decrease the molar ratio of dye to protein or allow the reaction to proceed for a shorter time.

Inefficient removal of free dye. Although we have had good success in removing free dye from protein conjugates with the provided columns, it is possible that trace amounts of free dye will remain in the conjugate solution after purification, particularly if a low molecular weight protein is labeled. The presence

of free dye, which can be determined by thin layer chromatography, will result in erroneously high calculated values for the degree of labeling (see *Determination of Degree of Labeling*). Remaining traces of free dye can be removed by applying the conjugate to another column or by extensive dialysis.

Product List *Current prices may be obtained from our Web site or from our Customer Service Department.*

Cat #	Product Name	Unit Size
A20170	Alexa Fluor® 633 Protein Labeling Kit *3 labelings*	1 kit

Contact Information

Further information on Molecular Probes products, including product bibliographies, is available from your local distributor or directly from Molecular Probes. Customers in Europe, Africa and the Middle East should contact our office in Paisley, United Kingdom. All others should contact our Technical Assistance Department in Eugene, Oregon.

Please visit our Web site — www.probes.com — for the most up-to-date information

Molecular Probes, Inc.

29851 Willow Creek Road, Eugene, OR 97402
Phone: (541) 465-8300 • Fax: (541) 335-0504

Customer Service: 6:00 am to 4:30 pm (Pacific Time)
Phone: (541) 335-0338 • Fax: (541) 335-0305 • order@probes.com

Toll-Free Ordering for USA and Canada:
Order Phone: (800) 438-2209 • Order Fax: (800) 438-0228

Technical Assistance: 8:00 am to 4:00 pm (Pacific Time)
Phone: (541) 335-0353 • Toll-Free: (800) 438-2209
Fax: (541) 335-0238 • tech@probes.com

Invitrogen European Headquarters

Invitrogen, Ltd.
3 Fountain Drive
Inchinnan Business Park
Paisley PA4 9RF, UK
Phone: +44 (0) 141 814 6100 • Fax: +44 (0) 141 814 6260
Email: euroinfo@invitrogen.com
Technical Services: eurotech@invitrogen.com

Molecular Probes products are high-quality reagents and materials intended for research purposes only. These products must be used by, or directly under the supervision of, a technically qualified individual experienced in handling potentially hazardous chemicals. Please read the Material Safety Data Sheet provided for each product; other regulatory considerations may apply.

Limited Use Label License No. 183: Alexa Fluor® Dyes

The manufacture, use, sale or import of this product is subject to one or more of U.S. Patent Nos. 5,696,157, 6,130,101, and 6,716,979, and corresponding foreign equivalents, owned by Invitrogen Corp. The purchase of this product conveys to the buyer the non-transferable right to use the purchased amount of the product and components of the product in research conducted by the buyer (whether the buyer is an academic or for-profit entity). The buyer cannot sell or otherwise transfer (a) this product (b) its components or (c) materials made using this product or its components to a third party or otherwise use this product or its components or materials made using this product or its components for Commercial Purposes. The buyer may transfer information or materials made through the use of this product to a scientific collaborator, provided that such transfer is not for any Commercial Purpose, and that such collaborator agrees in writing (a) to not transfer such materials to any third party, and (b) to use such transferred materials and/or information solely for research and not for Commercial Purposes. Commercial Purposes means any activity by a party for consideration and may include, but is not limited to: (1) use of the product or its components in manufacturing; (2) use of the product or its components to provide a service, information, or data; (3) use of the product or its components for therapeutic, diagnostic or prophylactic purposes; or (4) resale of the product or its components, whether or not such product or its components are resold for use in research. Invitrogen Corporation will not assert a claim against the buyer of infringement of the above patents based upon the manufacture, use or sale of a therapeutic, clinical diagnostic, vaccine or prophylactic product developed in research by the buyer in which this product or its components was employed, provided that neither this product nor any of its components was used in the manufacture of such product. If the purchaser is not willing to accept the limitations of this limited use statement, Invitrogen is willing to accept return of the product with a full refund. For information on purchasing a license to this product for purposes other than research, contact Molecular Probes, Inc., Business Development, 29851 Willow Creek Road, Eugene, OR 97402, Tel: (541)465-8300. Fax: (541)335-0504. All names containing the designation ® are registered with the U.S. Patent and Trademark Office.

Copyright 2004, Molecular Probes, Inc. All rights reserved. This information is subject to change without notice.