

PRODUCT INFORMATION & MANUAL

Human total IgG Platinum ELISA

BMS2091 / BMS2091TEN

Enzyme-linked Immunosorbent Assay for
quantitative detection of human total IgG.

For research use only.

Not for diagnostic or therapeutic procedures.



Human total IgG Platinum ELISA

North America

Technical Support:

Research Products:
888.810.6168
858.642.2058
tech@eBioscience.com

Clinical Products:
877.726.8559
858.642.2058
tech@eBioscience.com

Customer Service:

888.999.1371
858.642.2058
info@eBioscience.com

Fax:

858.642.2046

Europe/International*

Technical Support:

+43 1 796 40 40-120
tech@eBioscience.com

Customer Service:

+43 1 796 40 40-304
info@eBioscience.com

Fax:

+43 1 796 40 40-400



Bender MedSystems GmbH
Campus Vienna Biocenter 2
1030 Vienna, Austria
www.eBioscience.com

* Customers outside North America and Europe may contact their eBioscience distributor listed on our website at www.eBioscience.com/distributors.

TABLE OF CONTENTS

1	Intended Use	3
2	Summary	3
3	Principles of the Test	4
4	Reagents Provided	5
5	Storage Instructions – ELISA Kit	7
6	Specimen Collection and Storage Instructions	7
7	Materials Required But Not Provided	8
8	Precautions for Use	9
9	Preparation of Reagents	11
10	Test Protocol	16
11	Calculation of Results	20
12	Limitations	24
13	Performance Characteristics	25
14	Ordering Information	30
15	Reagent Preparation Summary	31
16	Test Protocol Summary	32

1 Intended Use

The human total IgG ELISA is an enzyme-linked immunosorbent assay for the quantitative detection of human total IgG. **The human total IgG ELISA is for research use only. Not for diagnostic or therapeutic procedures.**

2 Summary

IgG is the major immunoglobulin in blood, lymph fluid, cerebrospinal fluid, and peritoneal fluid and a key player in the humoral immune response. Serum IgG in healthy humans presents approximately 15% of total protein beside albumins, enzymes, other globulins and many more.

The Fc portion of IgG, but not F(ab')₂ or Fab fragments, can cross the placenta of a mother to enter the fetal circulation providing the fetus with postpartum protection.

IgG molecules are able to react with Fcγ receptors that are present on the surfaces of macrophages, neutrophils, natural killer cells, and can activate the complement system.

The binding of the Fc portion of IgG to the receptor present on a phagocyte is a critical step in the opsonizing property IgG provides to the immune response. Phagocytosis of particles coated with IgG antibodies is a vital mechanism to cope with microorganisms.

IgG is produced in a delayed response to an infection and can be retained in the body for a long time. The longevity in serum makes IgG most useful for passive immunization by transfer of this antibody. Detection of IgG usually indicates a prior infection or vaccination.

For literature update refer to **www.eBioscience.com**

3 Principles of the Test

An anti-human total IgG coating antibody is adsorbed onto microwells.

Coated Microwell

Figure 1

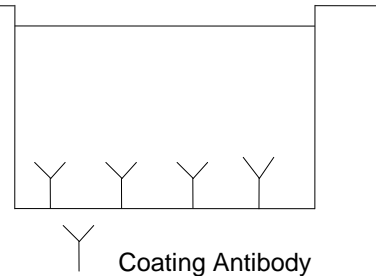

Human total IgG present in the sample or standard binds to antibodies adsorbed to the microwells and a HRP-conjugated anti-human total IgG antibody is added and binds to human total IgG captured by the first antibody.

First Incubation

Figure 2

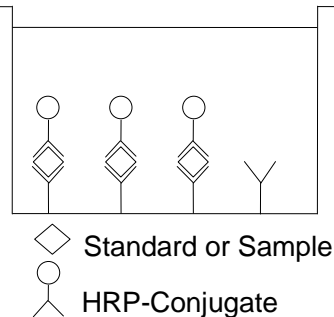

Following incubation unbound HRP-conjugated anti-human total IgG antibody is removed during a wash step, and substrate solution reactive with HRP is added to the wells.

Second Incubation

Figure 3

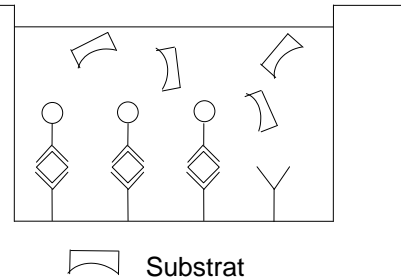

A coloured product is formed in proportion to the amount of human total IgG present in the sample or standard. The reaction is terminated by addition of acid and absorbance is measured at 450 nm. A standard curve is prepared from 7 human total IgG standard dilutions and human total IgG sample concentration determined.

Third Incubation

Figure 4

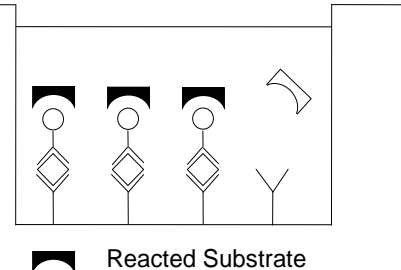

4 Reagents Provided

4.1 Reagents for human total IgG ELISA BMS2091 (96 tests)

- 1 aluminium pouch with a **Microwell Plate coated** with monoclonal antibody to human total IgG
- 1 vial (70 µl) **HRP-Conjugate** anti-human total IgG monoclonal antibody
- 2 vials human total IgG **Standard** lyophilized, 0.2 µg/ml upon reconstitution*
- 2 vial (5 ml) **Assay Buffer Concentrate** 20x (PBS with 1% Tween 20 and 10% BSA)
- 1 bottle (50 ml) **Wash Buffer Concentrate** 20x (PBS with 1% Tween 20)
- 1 vial (15 ml) **Substrate Solution** (tetramethyl-benzidine)
- 1 vial (15 ml) **Stop Solution** (1M Phosphoric acid)
- 1 vial (0.4 ml) **Blue-Dye**
- 1 vial (0.4 ml) **Green-Dye**
- 2 **Adhesive Films**

4.2 Reagents for human total IgG ELISA BMS2091TEN(10x96 tests)

- 10 aluminium pouches with a **Microwell Plate coated** with monoclonal antibody to human total IgG
- 10 vials (70 µl) **HRP-Conjugate** anti-human total IgG monoclonal antibody
- 10 vials human total IgG **Standard** lyophilized, 0.2 µg/ml upon reconstitution*
- 15 vials (5 ml) **Assay Buffer Concentrate 20x**
(PBS with 1% Tween 20 and 10% BSA)
- 4 bottles (50 ml) **Wash Buffer Concentrate 20x**
(PBS with 1% Tween 20)
- 10 vials (15 ml) **Substrate Solution** (tetramethyl-benzidine)
- 10 vials (15 ml) **Stop Solution** (1M Phosphoric acid)
- 6 vials (0.4 ml) **Blue-Dye**
- 6 vials (0.4 ml) **Green-Dye**
- 10 **Adhesive Films**

5 Storage Instructions – ELISA Kit

Store kit reagents between 2°C and 8°C. Immediately after use remaining reagents should be returned to cold storage (2°C to 8°C). Expiry of the kit and reagents is stated on labels.

Expiry of the kit components can only be guaranteed if the components are stored properly, and if, in case of repeated use of one component, this reagent is not contaminated by the first handling.

6 Specimen Collection and Storage Instructions

Serum and plasma (citrate, heparin, EDTA) were tested with this assay. Other biological samples might be suitable for use in the assay.

Samples containing a visible precipitate must be clarified prior to use in the assay. Do not use grossly hemolyzed or lipemic specimens.

Samples should be aliquoted and must be stored frozen at -20°C to avoid loss of bioactive human total IgG.

Avoid repeated freeze-thaw cycles. Prior to assay, the frozen sample should be brought to room temperature slowly and mixed gently.

7 Materials Required But Not Provided

- 5 ml and 10 ml graduated pipettes
- 5 μ l to 1000 μ l adjustable single channel micropipettes with disposable tips
- 50 μ l to 300 μ l adjustable multichannel micropipette with disposable tips
- Multichannel micropipette reservoir
- Beakers, flasks, cylinders necessary for preparation of reagents
- Device for delivery of wash solution (multichannel wash bottle or automatic wash system)
- Microwell strip reader capable of reading at 450 nm (620 nm as optional reference wave length)
- Glass-distilled or deionized water
- Statistical calculator with program to perform regression analysis

8 Precautions for Use

- All reagents should be considered as potentially hazardous. We therefore recommend that this product is handled only by those persons who have been trained in laboratory techniques and that it is used in accordance with the principles of good laboratory practice. Wear suitable protective clothing such as laboratory overalls, safety glasses and gloves. Care should be taken to avoid contact with skin or eyes. In the case of contact with skin or eyes wash immediately with water. See material safety data sheet(s) and/or safety statement(s) for specific advice.
- Reagents are intended for research use only and are not for use in diagnostic or therapeutic procedures.
- Do not mix or substitute reagents with those from other lots or other sources.
- Do not use kit reagents beyond expiration date on label.
- Do not expose kit reagents to strong light during storage or incubation.
- Do not pipette by mouth.
- Do not eat or smoke in areas where kit reagents or samples are handled.
- Avoid contact of skin or mucous membranes with kit reagents or specimens.
- Rubber or disposable latex gloves should be worn while handling kit reagents or specimens.
- Avoid contact of substrate solution with oxidizing agents and metal.
- Avoid splashing or generation of aerosols.
- In order to avoid microbial contamination or cross-contamination of reagents or specimens which may invalidate the test use disposable pipette tips and/or pipettes.
- Use clean, dedicated reagent trays for dispensing the conjugate and substrate reagent.

- Exposure to acid inactivates the conjugate.
- Glass-distilled water or deionized water must be used for reagent preparation.
- Substrate solution must be at room temperature prior to use.
- Decontaminate and dispose specimens and all potentially contaminated materials as they could contain infectious agents. The preferred method of decontamination is autoclaving for a minimum of 1 hour at 121.5°C.
- Liquid wastes not containing acid and neutralized waste may be mixed with sodium hypochlorite in volumes such that the final mixture contains 1.0% sodium hypochlorite. Allow 30 minutes for effective decontamination. Liquid waste containing acid must be neutralized prior to the addition of sodium hypochlorite.

9 Preparation of Reagents

Buffer Concentrates should be brought to room temperature and should be diluted before starting the test procedure.

If crystals have formed in the **Buffer Concentrates**, warm them gently until they have completely dissolved.

9.1 Wash Buffer (1x)

Pour entire contents (50 ml) of the **Wash Buffer Concentrate** (20x) into a clean 1000 ml graduated cylinder. Bring to final volume of 1000 ml with glass-distilled or deionized water. Mix gently to avoid foaming.

Transfer to a clean wash bottle and store at 2° to 25°C. Please note that Wash Buffer (1x) is stable for 30 days.

Wash Buffer (1x) may also be prepared as needed according to the following table:

Number of Strips	Wash Buffer Concentrate (20x) (ml)	Distilled Water (ml)
1 - 6	25	475
1 - 12	50	950

9.2 Assay Buffer (1x)

Pour the entire contents (5 ml) of the **Assay Buffer Concentrate (20x)** into a clean 100 ml graduated cylinder. Bring to final volume of 100 ml with distilled water. Mix gently to avoid foaming.

Store at 2° to 8°C. Please note that the Assay Buffer (1x) is stable for 30 days.

Assay Buffer (1x) may also be prepared as needed according to the following table:

Number of Strips	Assay Buffer Concentrate (20x) (ml)	Distilled Water (ml)
1 - 6	5.0	95.0
1 - 12	10.0	190.0

9.3 HRP-Conjugate

Please note that the HRP-Conjugate should be used within 30 minutes after dilution.

Make a 1:100 dilution of the concentrated **HRP-Conjugate** solution with Assay Buffer (1x) in a clean plastic tube as needed according to the following table:

Number of Strips	HRP-Conjugate (ml)	Assay Buffer (1x) (ml)
1 - 6	0.03	2.97
1 - 12	0.06	5.94

9.4 Human total IgG Standard

Reconstitute **human total IgG standard** by addition of distilled water. Reconstitution volume is stated on the label of the standard vial. Swirl or mix gently to insure complete and homogeneous solubilization (concentration of reconstituted standard = 0.2 µg/ml).

Allow the standard to reconstitute for 10-30 minutes. Mix well prior to making dilutions.

The standard has to be used immediately after reconstitution and cannot be stored.

Standard dilutions can be prepared directly on the microwell plate (see 10.e) or alternatively in tubes (see 9.4.1).

9.4.1 External Standard Dilution

Label 7 tubes, one for each standard point.

S1, S2, S3, S4, S5, S6, S7

Then prepare 2-fold serial dilutions for the standard curve as follows:

Pipette 225 µl of Assay Buffer (1x) into each tube.

Pipette 225 µl of reconstituted standard (concentration = 0.2 µg/ml) into the first tube, labelled S1, and mix (concentration of S1 = 0.1 µg/ml).

Pipette 225 µl of this dilution into the second tube, labelled S2, and mix thoroughly before the next transfer.

Repeat serial dilutions 5 more times thus creating the points of the standard curve (see Figure 5).

Assay Buffer (1x) serves as blank.

Figure 5

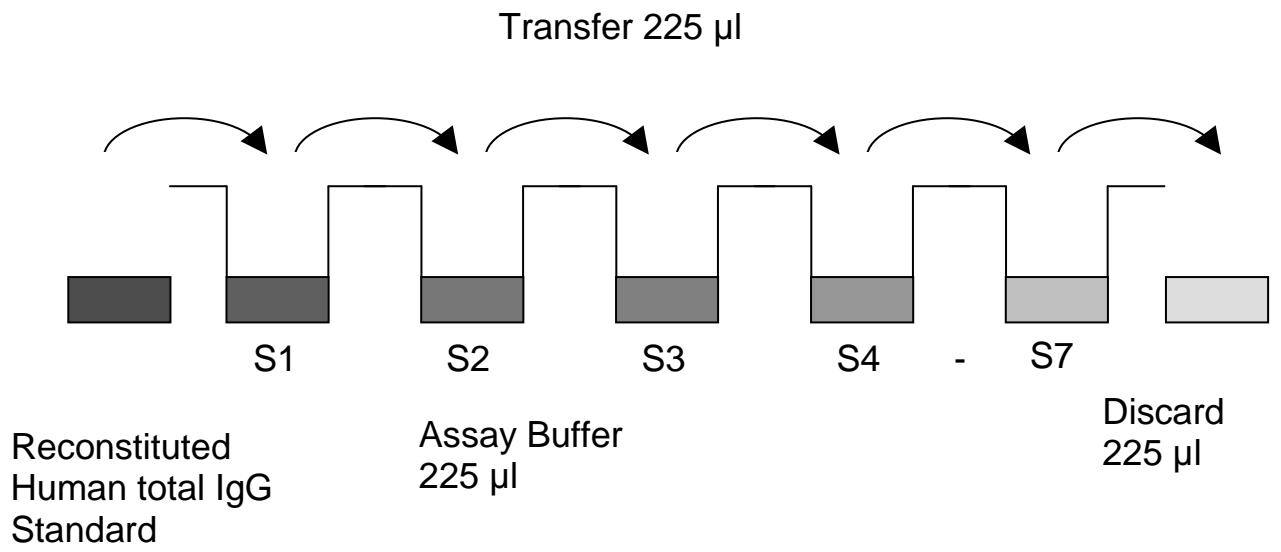

9.5 Addition of Colour-giving Reagents: Blue-Dye, Green-Dye

In order to help our customers to avoid any mistakes in pipetting the eBioscience ELISAs, eBioscience offers a tool that helps to monitor the addition of even very small volumes of a solution to the reaction well by giving distinctive colours to each step of the ELISA procedure.

This procedure is optional, does not in any way interfere with the test results, and is designed to help the customer with the performance of the test, but can also be omitted, just following the instruction booklet.

Alternatively, the dye solutions from the stocks provided (**Blue-Dye**, **Green-Dye**) can be added to the reagents according to the following guidelines:

1. Diluent:

Before standard and sample dilution add the **Blue-Dye** at a dilution of 1:250 (see table below) to the appropriate diluent (1x) according to the test protocol. After addition of **Blue-Dye**, proceed according to the instruction booklet.

5 ml Assay Buffer (1x)	20 µl Blue-Dye
12 ml Assay Buffer (1x)	48 µl Blue-Dye
50 ml Assay Buffer (1x)	200 µl Blue-Dye

2. Streptavidin-HRP:

Before dilution of the concentrated Biotin-Conjugate, add the **Green-Dye** at a dilution of 1:100 (see table below) to the Assay Buffer (1x) used for the final conjugate dilution. Proceed after addition of **Green-Dye** according to the instruction booklet: Preparation of Streptavidin-HRP Mixture.

3 ml Assay Buffer (1x)	30 µl Green-Dye
6 ml Assay Buffer (1x)	60 µl Green-Dye

10 Test Protocol

- a. Predilute your samples before starting with the test procedure. Dilute serum and plasma samples 1:500,000 with Assay Buffer (1x) according to the following scheme:

10 µl sample + 990 µl Assay Buffer (1x) = Predilution A
 10 µl Predilution A + 990 µl Assay Buffer (1x) = Predilution B
 10 µl Predilution B + 490 µl Assay Buffer (1x) = Final Predilution
- b. Determine the number of microwell strips required to test the desired number of samples plus appropriate number of wells needed for running blanks and standards. Each sample, standard, blank and optional control sample should be assayed in duplicate. Remove extra microwell strips from holder and store in foil bag with the desiccant provided at 2°-8°C sealed tightly.
- c. Prepare **HRP-conjugated** antibody (see Preparation of HRP-conjugated antibody 9.3).
- d. Wash the microwell strips twice with approximately 400 µl **Wash Buffer** per well with thorough aspiration of microwell contents between washes. Allow the Wash Buffer to sit in the wells for about **10 – 15 seconds** before aspiration. Take care not to scratch the surface of the microwells.
 After the last wash step, empty wells and tap microwell strips on absorbent pad or paper towel to remove excess Wash Buffer. Use the microwell strips immediately after washing. Alternatively microwell strips can be placed upside down on a wet absorbent paper for not longer than 15 minutes. **Do not allow wells to dry.**
- e. **Standard dilution on the microwell plate** (Alternatively the standard dilution can be prepared in tubes – see 9.4.1):
 Add 100 µl of Assay Buffer (1x) in duplicate to all **standard wells**. Pipette 100 µl of prepared **standard** (see Preparation of Standard 0, concentration = 0.2 µg/ml), in duplicate, into well A1 and A2 (see Table 1). Mix the contents of wells A1 and A2 by repeated aspiration and ejection (concentration of standard 1 S1 = 0.1 µg/ml), and transfer 100 µl to wells B1 and B2, respectively (see Figure 6). Take care not to scratch the inner surface of the microwells. Continue this procedure 5 times, creating two rows of human total IgG standard dilutions, ranging from 0.1 µg/ml to 0.002 µg/ml. Discard 100 µl of the contents from the last microwells (S7) used.

Figure 6

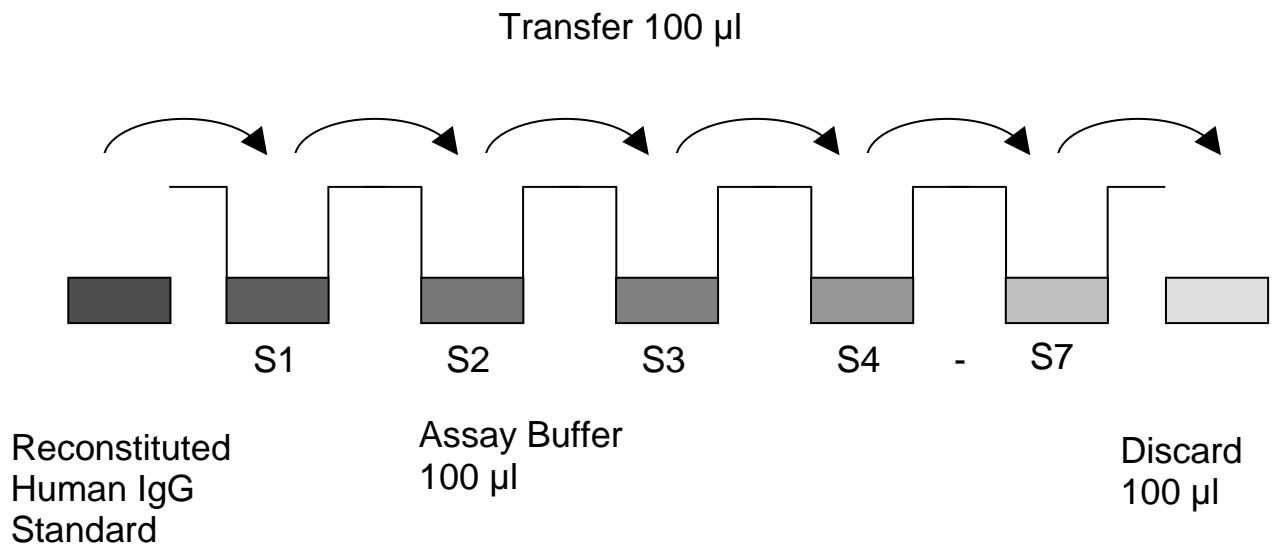

In case of an **external standard dilution** (see 9.4.1), pipette 100 μ l of these standard dilutions (S1 – S7) in the standard wells according to Table 1.

Table 1

Table depicting an example of the arrangement of blanks, standards and samples in the microwell strips:

	1	2	3	4
A	Standard 1 (0.1 μ g/ml)	Standard 1 (0.1 μ g/ml)	Sample 1	Sample 1
B	Standard 2 (0.05 μ g/ml)	Standard 2 (0.05 μ g/ml)	Sample 2	Sample 2
C	Standard 3 (0.025 μ g/ml)	Standard 3 (0.025 μ g/ml)	Sample 3	Sample 3
D	Standard 4 (0.013 μ g/ml)	Standard 4 (0.013 μ g/ml)	Sample 4	Sample 4
E	Standard 5 (0.006 μ g/ml)	Standard 5 (0.006 μ g/ml)	Sample 5	Sample 5
F	Standard 6 (0.003 μ g/ml)	Standard 6 (0.003 μ g/ml)	Sample 6	Sample 6
G	Standard 7 (0.002 μ g/ml)	Standard 7 (0.002 μ g/ml)	Sample 7	Sample 7
H	Blank	Blank	Sample 8	Sample 8

- f. Add 100 µl of Assay Buffer in duplicate to the **blank wells**.
- g. Add 100 µl of each final prediluted sample in duplicate to the **sample wells**.
- h. Add 50 µl of diluted **HRP-conjugated antibody** to all wells, including the blank wells.
- i. Cover with an adhesive film and incubate at room temperature (18 to 25°C) for 1 hour, if available on a microplate shaker set at 400 rpm.
- j. Remove adhesive film and empty wells. **Wash** microwell strips 4 times according to point b of the test protocol. Proceed immediately to the next step.
- k. Pipette 100 µl of **TMB Substrate Solution** to all wells.
- l. Incubate the microwell strips at room temperature (18° to 25°C) for 30 minutes. Avoid direct exposure to intense light.

The colour development on the plate should be monitored and the substrate reaction stopped (see next point of this protocol) before positive wells are no longer properly recordable. Determination of the ideal time period for colour development has to be done individually for each assay.

It is recommended to add the stop solution when the highest standard has developed a dark blue colour. Alternatively the colour development can be monitored by the ELISA reader at 620 nm. The substrate reaction should be stopped as soon as Standard 1 has reached an OD of 0.9 – 0.95.

- m. Stop the enzyme reaction by quickly pipetting 100 µl of **Stop Solution** into each well. It is important that the Stop Solution is spread quickly and uniformly throughout the microwells to completely inactivate the enzyme. Results must be read immediately after the Stop Solution is added or within one hour if the microwell strips are stored at 2 - 8°C in the dark.

- n. Read absorbance of each microwell on a spectro-photometer using 450 nm as the primary wave length (optionally 620 nm as the reference wave length; 610 nm to 650 nm is acceptable). Blank the plate reader according to the manufacturer's instructions by using the blank wells. Determine the absorbance of both the samples and the standards.

Note: In case of incubation without shaking the obtained O.D. values may be lower than indicated below. Nevertheless the results are still valid.

***NOTE: If instructions of this protocol have been followed samples have been diluted 1:500 000, the concentration read from the standard curve must be multiplied by the dilution factor (x500 000).**

11 Calculation of Results

- Calculate the average absorbance values for each set of duplicate standards and samples. Duplicates should be within 20 per cent of the mean value.
- Create a standard curve by plotting the mean absorbance for each standard concentration on the ordinate against the human total IgG concentration on the abscissa. Draw a best fit curve through the points of the graph (a 5-parameter curve fit is recommended).
- To determine the concentration of circulating human total IgG for each sample, first find the mean absorbance value on the ordinate and extend a horizontal line to the standard curve. At the point of intersection, extend a vertical line to the abscissa and read the corresponding human total IgG concentration.
- **If instructions in this protocol have been followed samples have been diluted 1:500,000, the concentration read from the standard curve must be multiplied by the dilution factor (x 500,000).**
- It is suggested that each testing facility establishes a control sample of known human total IgG concentration and runs this additional control with each assay. If the values obtained are not within the expected range of the control, the assay results may be invalid.
- A representative standard curve is shown in Figure 7. This curve cannot be used to derive test results. Each laboratory must prepare a standard curve for each group of microwell strips assayed.

Representative standard curve for human total IgG ELISA. Human total IgG was diluted in serial 2-fold steps in Assay Buffer (1x). Do not use this standard curve to derive test results. A standard curve must be run for each group of microwell strips assayed.

Figure 7

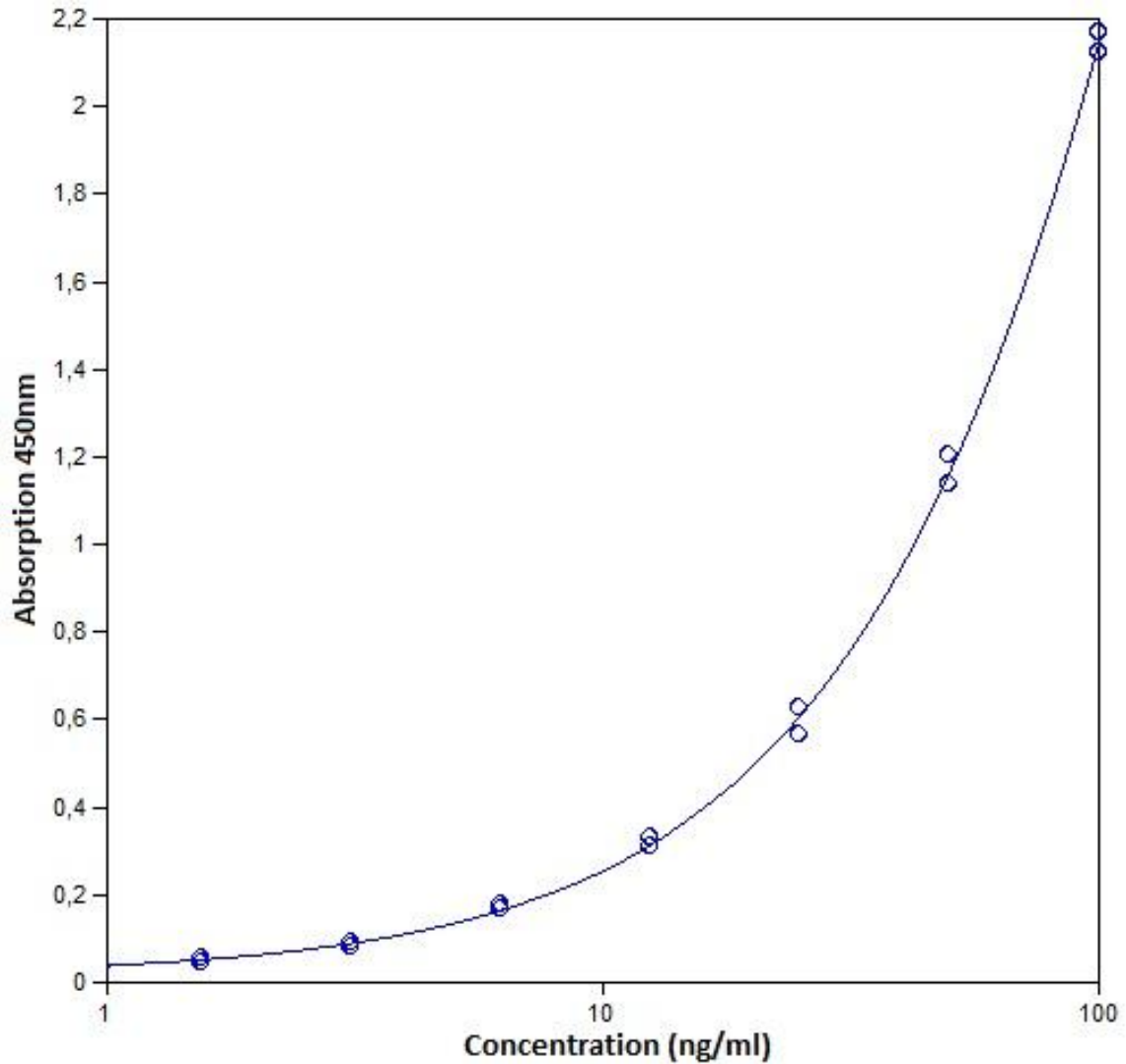

Table 2

Typical data using the human total IgG ELISA

Measuring wavelength: 450 nm

Reference wavelength: 620 nm

Standard	human total IgG Concentration (µg/ml)	O.D. at 450 nm	Mean O.D. at 450 nm	C.V. (%)
1	0.1	2.213 2.169	2.191	1.0%
2	0.05	1.182 1.248	1.215	2.7%
3	0.025	0.613 0.671	0.642	4.6%
4	0.013	0.358 0.376	0.367	2.5%
5	0.006	0.213 0.224	0.219	2.7%
6	0.003	0.128 0.136	0.132	3.3%
7	0.002	0.092 0.099	0.095	3.4%
Blank	0.0	0.048 0.052	0.050	3.3%

The OD values of the standard curve may vary according to the conditions of assay performance (e.g. operator, pipetting technique, washing technique or temperature effects). Furthermore shelf life of the kit may affect enzymatic activity and thus colour intensity. Values measured are still valid.

12 Limitations

- Since exact conditions may vary from assay to assay, a standard curve must be established for every run.
- Bacterial or fungal contamination of either screen samples or reagents or cross-contamination between reagents may cause erroneous results.
- Disposable pipette tips, flasks or glassware are preferred, reusable glassware must be washed and thoroughly rinsed of all detergents before use.
- Improper or insufficient washing at any stage of the procedure will result in either false positive or false negative results. Empty wells completely before dispensing fresh wash solution, fill with Wash Buffer as indicated for each wash cycle and do not allow wells to sit uncovered or dry for extended periods.

13 Performance Characteristics

13.1 Sensitivity

The limit of detection of human total IgG defined as the analyte concentration resulting in an absorbance significantly higher than that of the dilution medium (mean plus 2 standard deviations) was determined to be 0.24 ng/ml (mean of 4 independent assays).

13.2 Reproducibility

13.2.1 Intra-assay

Reproducibility within the assay was evaluated in 3 independent experiments. Each assay was carried out with 3 replicates of 8 serum and plasma samples containing different concentrations of human total IgG. 2 standard curves were run on each plate. Data below show the mean human total IgG concentration and the coefficient of variation for each sample (see Table 3). The calculated overall intra-assay coefficient of variation was 5.3%.

Table 3

The mean human total IgG concentration and the coefficient of variation for each sample

Sample	Experiment	Mean human total IgG Concentration (µg/ml)	Coefficient of Variation (%)
1	1	13029.9	7.4%
	2	12462.9	2.5%
	3	12968.8	4.0%
2	1	6978.1	7.6%
	2	7059.7	2.9%
	3	7217.2	5.8%
3	1	12356.6	4.0%
	2	11742.0	5.4%
	3	12012.1	5.0%
4	1	7582.5	5.0%
	2	7673.2	3.4%
	3	7901.4	5.9%
5	1	7465.1	7.4%
	2	7194.2	12.3%
	3	8028.6	6.9%
6	1	11049.0	4.2%
	2	11238.4	4.1%
	3	10939.3	4.7%
7	1	8452.7	6.1%
	2	8873.5	6.9%
	3	8433.5	3.4%
8	1	11632.5	2.9%
	2	11489.1	3.7%
	3	11205.0	4.9%

13.2.2 Inter-assay

Assay to assay reproducibility within one laboratory was evaluated in 3 independent experiments. Each assay was carried out with 3 replicates of 8 serum and plasma samples containing different concentrations of human total IgG. 2 standard curves were run on each plate. Data below show the mean human total IgG concentration and the coefficient of variation calculated on 18 determinations of each sample (see Table 4). The calculated overall inter-assay coefficient of variation was 2.6%.

Table 4

The mean human total IgG concentration and the coefficient of variation of each sample

Sample	Mean human total IgG Concentration ($\mu\text{g/ml}$)	Coefficient of Variation (%)
1	12968.8	2.4
2	7217.2	1.7
3	12012.1	2.6
4	7901.4	2.1
5	8028.6	5.6
6	10939.3	1.4
7	8433.5	2.9
8	11205.0	1.9

13.3 Dilution Parallelism

Serum and plasma (EDTA, citrate, heparin) samples with different levels of human total IgG were analysed at serial 2 fold dilutions with 4 replicates each.

For data see Table 5.

Table 5

Sample matrix	Recovery of Exp. Val.		
	Dilution	Mean (%)	Range (%)
Serum	1:1,000,000	83	74-91
	1:2,000,000	80	77-82
	1:4,000,000	86	75-97
Plasma (EDTA)	1:1,000,000	94	81-106
	1:2,000,000	93	89-102
	1:4,000,000	83	71-93
Plasma (citrate)	1:1,000,000	81	68-89
	1:2,000,000	86	79-100
	1:4,000,000	83	73-96
Plasma (heparin)	1:1,000,000	87	76-99
	1:2,000,000	90	81-98
	1:4,000,000	85	69-99

13.4 Sample Stability

13.4.1 Freeze-Thaw Stability

Aliquots of serum and plasma samples (spiked or unspiked) were stored at -20°C and thawed 3 times, and the human total IgG levels determined.

There was no significant loss of human total IgG immunoreactivity detected by freezing and thawing.

13.4.2 Storage Stability

Aliquots of serum, plasma, cell culture supernatant samples (spiked or unspiked) were stored at -20°C, 2-8°C, room temperature (RT) and at 37°C, and the human total IgG level determined after 24 h.

There was no significant loss of human total IgG immunoreactivity detected during storage under above conditions.

13.5 Specificity

The assay detects both natural and recombinant human total IgG. The cross reactivity and interference of circulating factors of the immune system was evaluated by spiking these proteins at physiologically relevant concentrations into a human total IgG positive sample.

There was no cross reactivity or interference detected.

13.6 Expected Values

Panels of 20 serum as well as plasma samples (EDTA, citrate, heparin) from randomly selected healthy donors (males and females) were tested for human total IgG.

Table 6

Sample Matrix	Number of Samples Evaluated	Mean mg/ml	Range mg/ml	Standard Deviation mg/ml
Serum	20	13	4.4-21.3	29%
Plasma (EDTA)	20	20.4	12.9-29.9	21%
Plasma (Citrate)	20	6.7	2.1-14.7	39%
Plasma (Heparin)	20	11.2	5.9-19.1	31%

14 Ordering Information

North America

Technical Support:

Research Products:
888.810.6168
858.642.2058
tech@eBioscience.com

Clinical Products:
877.726.8559
858.642.2058
tech@eBioscience.com

Customer Service:

888.999.1371
858.642.2058
info@eBioscience.com

Fax:

858.642.2046

Europe/International*

Technical Support:

+43 1 796 40 40-120
tech@eBioscience.com

Customer Service:

+43 1 796 40 40-304
info@eBioscience.com

Fax:

+43 1 796 40 40-400



Bender MedSystems GmbH
Campus Vienna Biocenter 2
1030 Vienna, Austria
www.eBioscience.com

* Customers outside North America and Europe may contact their eBioscience distributor listed on our website at www.eBioscience.com/distributors.

15 Reagent Preparation Summary

15.1 Wash Buffer (1x)

Add **Wash Buffer Concentrate** 20x (50 ml) to 950 ml distilled water.

Number of Strips	Wash Buffer Concentrate (ml)	Distilled Water (ml)
1 - 6	25	475
1 - 12	50	950

15.2 Assay Buffer (1x)

Add **Assay Buffer Concentrate** 20x (5 ml) to 95 ml distilled water.

Number of Strips	Assay Buffer Concentrate (ml)	Distilled Water (ml)
1 - 6	5.0	95.0
1 - 12	10.0	190.0

15.3 HRP-Conjugate

Make a 1:100 dilution of the concentrated **HRP-Conjugate** solution with Assay Buffer (1x) in a clean plastic tube as needed according to the following table:

Number of Strips	HRP-Cojugate (ml)	Assay Buffer (1x) (ml)
1 - 6	0.03	2.97
1 - 12	0.06	5.94

15.4 Human total IgG Standard

Reconstitute **human total IgG standard** with distilled water.
(Reconstitution volume is stated on the label of the standard vial.)

16 Test Protocol Summary

1. Predilute your samples with Assay Buffer (1x) 1:500,000
2. Determine the number of microwell strips required.
3. Prepare HRP-Conjugate.
4. Wash microwell strips twice with Wash Buffer.
5. Standard dilution on the microwell plate: Add 100 µl Assay Buffer (1x), in duplicate, to all standard wells. Pipette 100 µl prepared standard into the first wells and create standard dilutions by transferring 100 µl from well to well. Discard 100 µl from the last wells.
Alternatively external standard dilution in tubes (see 9.4.1):
Pipette 100 µl of these standard dilutions in the microwell strips.
6. Add 100 µl of Assay Buffer in duplicate to the blank wells.
7. Add 100 µl of each final prediluted sample in duplicate to the sample wells.
8. Add 50 µl diluted HRP-Conjugate to all wells.
9. Cover microwell strips and incubate 1 hours at room temperature (18°-25°C) if available on a microplate shaker.
10. Empty and wash microwell strips 4 times with Wash Buffer.
11. Add 100 µl of TMB Substrate Solution to all wells.
12. Incubate the microwell strips for about 30 minutes at room temperature (18°C to 25°C)
13. Add 100 µl Stop Solution to all wells.
14. Blank microwell reader and measure colour intensity at 450 nm.